

# rollershades

60mm heavy duty hardware system



*Luxaflex*<sup>®</sup>

WINDOW FASHIONS

[www.luxaflex.co.nz](http://www.luxaflex.co.nz)

# rollershades

## 60mm heavy duty hardware system

### Product Specifications

The growing requirement for larger, heavier shades has led to the release of a new Rollershade hardware program. This innovative system has been engineered to meet both the functional and visual demands of modern architecture. The new heavy duty system can be operated using either a spring assisted chain mechanism or 50mm tubular motors.

### Exploded View Diagram

Flexi Glide Heavy Duty Rollershade

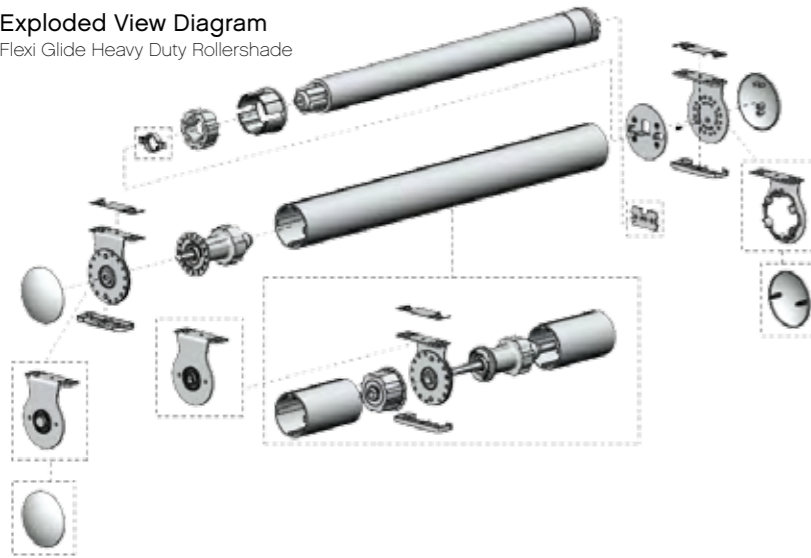

### Measuring Guide

The Heavy Duty Rollershade System is suitable for both face and reveal fit situations. Measuring instructions for this product are outlined below.

### Architrave & Reveal

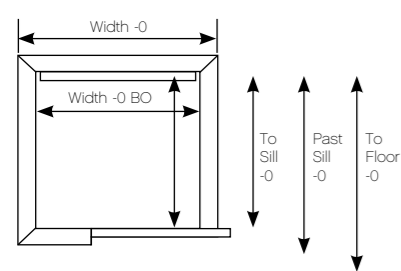

### Face & Reveal

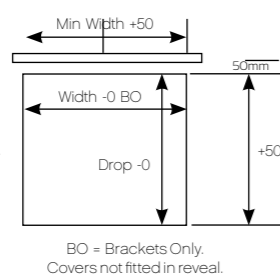

### Corners

\* CORNERS ON FACE  
40mm Proj Bkt deduct 75mm  
55mm Proj Bkt deduct 90mm

\* CORNERS IN REVEAL  
40mm Proj Bkt deduct 65mm  
55mm Proj Bkt deduct 80mm

NOTE: Windows in reveal brackets will be ceiling fixed.

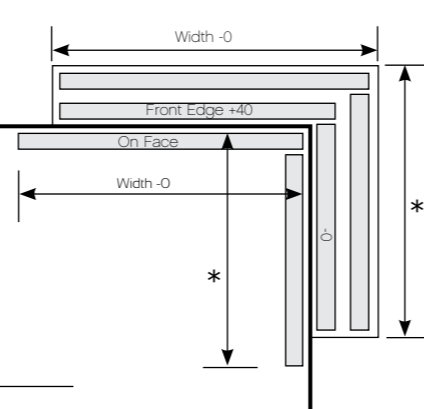

Multiple or Linked Blinds on Face or In Reveal  
- Measure to centre of mullions

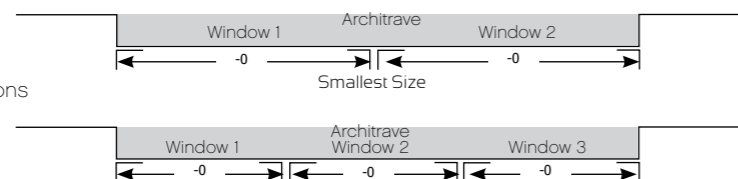

### Accessory Options

- Linked Operation
  - Plastic, Metal or Stainless Steel Chains
- Note: The Heavy Duty system is not available in a Dual Bracket configuration or with the Valance/Head Box option.

Please refer to your price guide for details on accessory surcharges.

### Component Options

Bottom rail round  
(White, Black, Ivory, Silver anodised, & Pearl bronze)

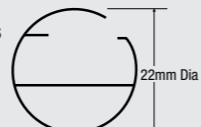

Elliptical  
(White, Black, Ivory, Silver anodised, & Pearl bronze)

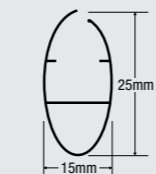

### gallery exclusive

balance bottom rail  
(black, white, anodised silver, & white birch (ivory))

size: depth = 16mm  
height = 32mm

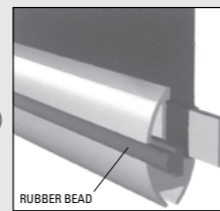

### Limitations

LUXAFLEX® Rollershade limitations have been developed to ensure the blind operates and performs to maximum potential. Measurements outside of these parameters may not perform to LUXAFLEX® Quality Standards and will be void of warranty.

	Chain Drive	Automated
Minimum Width	1200mm	850mm
Maximum Width	Fabric dependent - refer to your price guide for further details.	
Minimum Drop	1000mm	
Maximum Drop	Fabric dependent - refer to your price guide for further details.	
Maximum Linked Blinds	3 Blinds	

### models

- Clean, elegant appearance which combines the soft look of fabric with practical operating systems.
- Robust heavy duty Rollershade system with extended size limitation options [refer to your price guide for further details].
- Available with either a Spring Assisted Chain mechanism or Automated operation. Compatible with Somfy Motor Technology [as available].
- Minimum gap between blinds in a multiple linked system. Installation can be performed by a single installer for blinds up to 2.3m.
- Exceptionally quiet operation due to damping in component construction.



### Operating options - Chain Control (Spring Assisted)

The heavy duty chain control mechanism is designed for large Rollers. With the use of bearings and three types of spring assist boosters, large blinds can be manually controlled with a maximum operating effort of no more than 2.3 Kgs; at a 1:1 ratio.



### Automated

The new hardware system is compatible with Somfy 50mm motor technology.



### Bracket Dimensions

Chain Drive Control Side

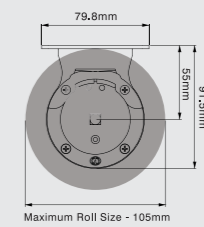

Chain Drive Idle End

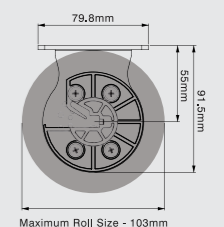

Automated Control Side

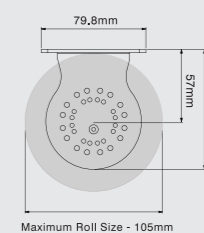

Automated Idle End

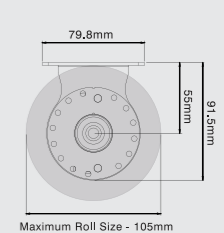

### Light Gaps

Chain Drive Blind

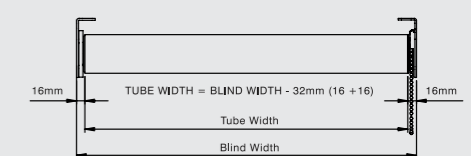

Automated Blind

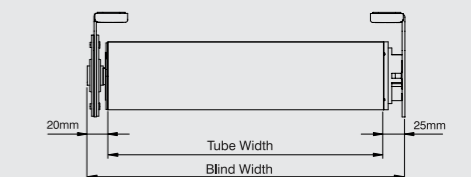

Linked Configuration

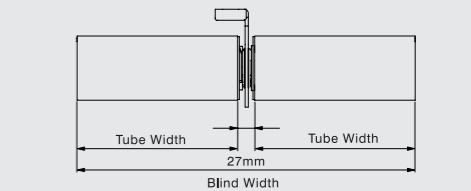

*Luxaflex*<sup>®</sup>

WINDOW FASHIONS

[www.luxaflex.co.nz](http://www.luxaflex.co.nz)

Available from your nearest LUXAFLEX<sup>®</sup> licensee. For a nationwide list of licensee retailers visit [www.luxaflex.co.nz](http://www.luxaflex.co.nz)

© Copyright 2010 New Zealand Window Shades ® Registered Trade Marks of New Zealand Window Shades  
® Somfy is a registered trade mark of Somfy Pty Limited (ABN 77 003 917 244)