



Sunscreens & Rollershades



Specification Guide

FEATURING QUANTUM ROLLERSHADE HARDWARE SYSTEM



Luxaflex[®]

Contents

Product Overview	4
Hardware Specification Overview	5
Gear Ratio	5
Energy Benefits	5
Fire Retardancy	5
Durability	5
Warranty	5
Luxaflex® Sunscreens	6
Maintaining the Outside View	7
Environmental and Employee Benefits	7
Shading	7
Heat Protection	7
Glare Reduction	7
Luxaflex® Rollershades	8
Teflon® Fabric Protector	9
Oeko Tex Certified	9
Blockout Fabric Selection Guide	9
Sanitized®	9
Fire Retardant	9
Duraguard® Fabric Protector	9
Operating Systems	10
Headbox System	11
Construction & Specification	15
Bottom Rail	15
Improved Ellipse Balance Rail	16
Inner Strength	16
Roller Shade Bracket Systems	17
Quality Aesthetics	17
Single Bracket	17
Single Bracket Cover	17
Twin Roller Brackets	17
Dual Roll Configuration	18
Single Bracket – Recessed Head Detail	18
Double Bracket – Recessed Head Detail	19
Chain Tensioners	19
Set 13 – Wire Guide System	20
Fixing Options	20
Operation Type Limitations	21
Fabric Specification Guide	22

Product Overview



Rollershades are both decorative and functional. The choice of fabrics is extensive, ranging from practical blockouts to the latest innovations in light controlling sunscreens.

Sunscreen Rollershades allow the building occupants to enjoy the view and natural light whilst providing low light transmission, glare reduction and excellent shading values.

Blockout Rollershades allow the building occupants to enjoy complete room

darkening and privacy settings, ideal for boardroom, audio-visual theatre and bedroom applications.

All Sunscreen and Blockout Rollershades can be automated with remote control, wall switches or linked to Building Management Systems.

For more information please refer to the automation section of the Luxaflex® website www.luxaflex.co.nz

Hardware Specification Overview

Blockout Rollershades and Sunscreen

Rollershades are available with spring, chain or automated operating systems. Each system utilises extruded aluminium roller tube and hard-wearing UV resistant plastics.

Gear Ratio

The durable standard clutch is available in two ratio mechanisms 1:1 and 1:75. This enables a heavier blind to be lifted without the need of a spring booster. It is also aesthetically pleasing in one size format which is capable of lifting a range of shade weights.

Universal spring loaded idle ends provide for smooth and easy installation.

Energy Benefits

Shading that is fitted to a building provides significant reductions in solar heat gain, while reducing UV rays. Automated Sunscreens can be connected to Building Management Systems (BMS) for optimal control of air conditioning loads and comfort of the building occupants.

Fire Retardancy

Please refer to Fabric Specification Guide on page 22 of this document.



Durability

Glass fibre based fabrics possess inherent strength, dimensional stability and chemical resistance. Polyester fabrics are also available to provide environmentally friendly options while still offering high levels of performance. Sunscreens are naturally resistant to growth of mould and mildew and are easily cleaned.

Warranty

Rollershades installed as part of commercial fit-outs are covered by a 2 year warranty. Please refer to www.luxaflex.co.nz for terms and conditions.



Luxaflex[®] Sunscreens

Luxaflex[®] Sunscreens feature new generation fabrics providing the ultimate in light, glare and heat control while allowing continued enjoyment of the views.

Luxaflex[®] Sunscreens are perfect for any room heavily exposed to the sun, to reduce the glare and control heat coming through the window. While it's important to keep your home cool in summer by creating a barrier to the sun's heat, you also want to retain a level of natural light. With Luxaflex[®] Sunscreens you can enjoy the view outside, even when your blinds are completely down – all the while retaining a fashion-forward look that works with the aesthetic of your room.

Cut in our state-of-the-art factory using the latest in ultrasonic technology these revolutionary fabrics allow the flow of light

and ventilation by way of the 'openness factor' of the fabric, whilst reducing the impact of heat, glare and UV rays by up to 97%. Luxaflex[®] offer a wide range of sunscreen fabrics which are both technically superior and aesthetically unique. The polymer coated glass fibre range is woven to withstand the Australasian conditions whilst the new La Vista Sunscreen is woven from Polyester Yarn, providing both high levels of technical performance and long term environmental benefits.

Luxaflex[®] Sunscreen fabrics are available in a modern colour, texture and pattern range to suit your specific requirements. Protecting your environment from heat and glare does not mean compromising on style.

All fabrics are tested and comply with stringent Australian and New Zealand standards.

Maintaining the Outside View

The unique weave of Sunscreen fabrics allows a view through the fabric from the area of lesser light to the area of greater light. This means that during the day, building occupants can see through the fabric to the outside, while there is a high level of privacy from people looking from the outside into the building.

The darker the colour, the greater the amount of light transmitted, hence the better the view through the fabric. In fact, black fabric provides very little obstruction to the view outside.

Environmental and Employee Benefits

The light filtering effect of Sunscreens means that the use of natural light in the workplace can be maximised, which is important for individual productivity and well being as well as reducing the need for artificial lighting during the day.

Shading

Outside, sunlight can vary in strength from as much as 100,000 lux to less than 10,000 lux, but inside we need from 100 to 1000 lux, depending on the task. Most often we need a light level of 300-500 lux, so windows must be shaded to reduce the quantity of light entering the room.

As a rule of thumb, maximum luminance differences between the window, walls and computer screens should be 30:10:1. Sunscreens transmit around 5% to 25% of the outside light, depending on the weave and colour, and provide significant shading that supplements the shading provided by the glass.



Heat Protection

In warm climates like that of most of New Zealand, the need for heat protection is a key consideration in the comfort of the building occupants and the cost of cooling the building with air conditioning.

Luxaflex® also offer a range of fabrics that address heat retention issues. Sunscreens transmit as little as 7% of heat, depending on colour and weave. Lighter colours and less open fabrics reflect more heat than darker colours in more open weaves.

Sunscreens provide the greatest heat protection when fitted externally, as they stop most of the sun's rays before they reach the glass.

Glare Reduction

Reflections and high luminance variations cause eye discomfort, particularly where people are using computers. Sunscreens provide uniform shading across a window, eliminating light spots and annoying reflections. The darker the colour, the greater the glare reduction.

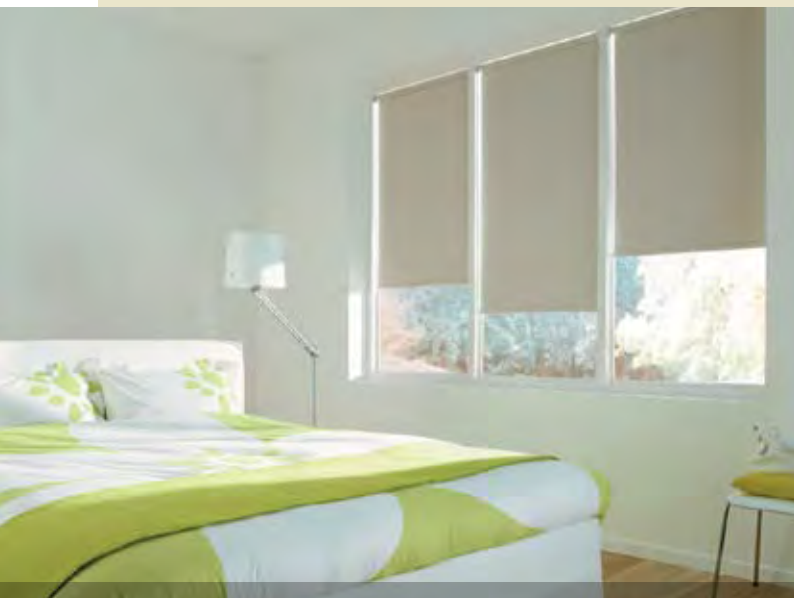



Luxaflex[®] Rollershades

Luxaflex[®] Rollershades offer the ultimate in style, colour and design coupled with hard-wearing durability.

Using premium grade components, Luxaflex[®] Rollershades are custom-made to suit individual requirements. Luxaflex[®] Rollershades are available with a number of operating systems including the standard chain drive, chainless spring motor or fully automated via wall switches or remote technology.

Whether you want to blend a window into the background or make it the feature of a room, it's so quick, easy and affordable with Luxaflex[®] Rollershades.

The beautiful yet durable Luxaflex[®] Rollershades Fabric Collection provides the ultimate colour and style from plain to textured, in a range of translucencies from light filtering to block-out. Luxaflex[®] fabrics are designed to suit both commercial and residential applications and address individual light, glare, heat and privacy needs, with a range of fabric features including Sanitized[®] for those sensitive to dust mites and odour or Duraguard[®], a repellent for most staining agents.

Whichever fabric you specify, the exclusive use of ultrasonic cutting technology will ensure fabric edges are sealed to enhance the performance and longevity of Luxaflex[®] Rollershades.

Teflon® Fabric Protector

This provides durable, long lasting protection against oil and water based stains, as well as dust and dry soil. The fabric looks newer for longer and is easier to take care of but does not affect the look, feel, colour, breathability or texture of the fabric.

Oeko Tex Certified

A globally uniform testing certification system, textile raw materials, intermediate and end products all meet the required specification for the exclusion of harmful substances.

Blockout Fabric Selection Guide

Please refer to www.luxaflex.co.nz for the current Blockout fabric range.

Sanitized®

Luxaflex® Blockout fabric options include an exclusive hygiene function treatment. With the New Zealand climate in mind we have developed a fabric treatment that inhibits the development of bacteria, fungi, dust mites and odour. This is welcome news for customers with respiratory issues such as asthma.



Fire Retardant

Another important feature of these Blockout fabrics is fire retardant, giving your customers extra peace of mind. This has been carefully formulated so it does not affect the texture and feel of the fabric, so they maintain their good looks and appearance.

Duraguard® Fabric Protector

Duraguard® has been exclusively developed for our company with the rigours that blinds have to face in mind. With this applied the fabric will repel most staining agents with its proven, water based, fluorochemical formula.

When spills like tea, coffee, oil or red wine come in contact with the treated fabric, the liquid forms beads and simply rolls off. This makes the fabric much easier to clean and keeps its pristine looks for longer.

Operating Systems



Set 12

Classic Chain Drive

With its classic design and simple appeal, the chain driven Rollershade is a practical operation with unobtrusive style in any situation. Providing a versatile, easy operating blind, which enables the blinds to be raised or lowered by means of a chain from either side and can be face fitted or in-reveal mounted. Chains available in colour coordinated and metal options.

Set: 12



Set 20

Linked Rollershades

Luxaflex® Sunscreens can be purchased in wider dimensions with the new linked roller blind system, which enables blinds to be operated with the one control. Ideal for applications such as bifolding doors.

Automation

Automated Luxaflex® Rollershades combine flexibility and convenience for enhanced internal comfort and control. The automated Rollershades incorporate European designed and manufactured motors and remote controls, providing silent movement of the blinds.



Set 71

Twin Bracket Sunscreens

Twin Rollershades allow you to combine the functionality of two different fabric translucencies in the one Rollershade system offering flexibility to adjust both light levels and night time privacy in the one application.

Set: 70, 71, 80, 81, 82, 92, 93



Gear Ratio

The durable standard clutch is available in two ratio mechanisms 1:1 and 1:75. This enables a heavier blind to be lifted without the need of a spring assist. It is also aesthetically pleasing in one size format which is capable of lifting a range of blind weights. Universal spring loaded idle ends provide for smooth and easy installation.

Child Safety

Child safety is a critical issue and one that Luxaflex® have addressed with the availability of child safety devices as options on your blinds. We continually monitor standards to ensure our Luxaflex® products comply with applicable safety standards and are safe for you and your child. Refer to page 19 of this document for child safe chain devices.

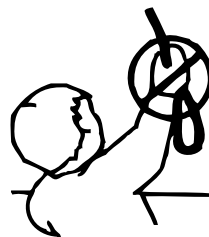

Headbox System

The contemporary headbox system has been designed to provide a simple slimline profile whilst at the same time maximising the drop capacity for your roller. The headbox is available in both silver anodised finish or a choice of powder coated colours (White, Black or Magnolia).



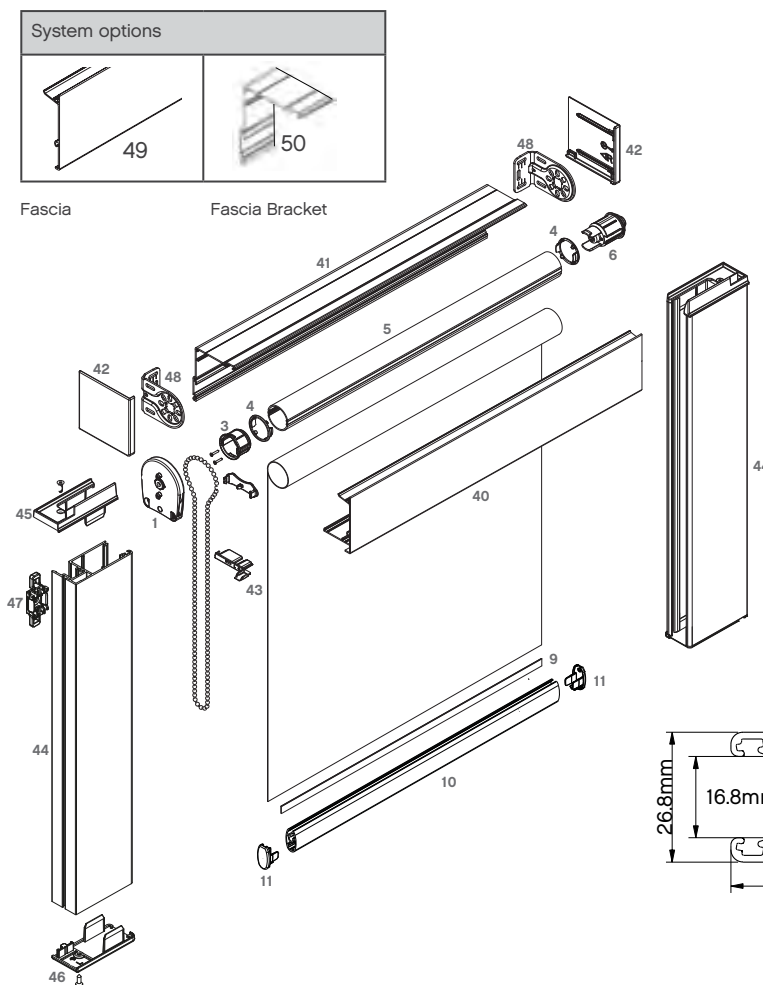

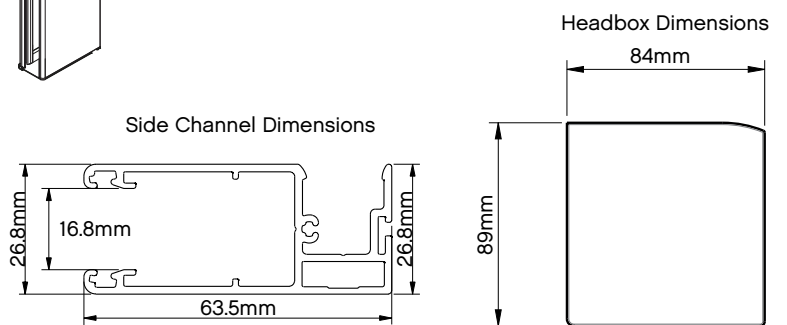
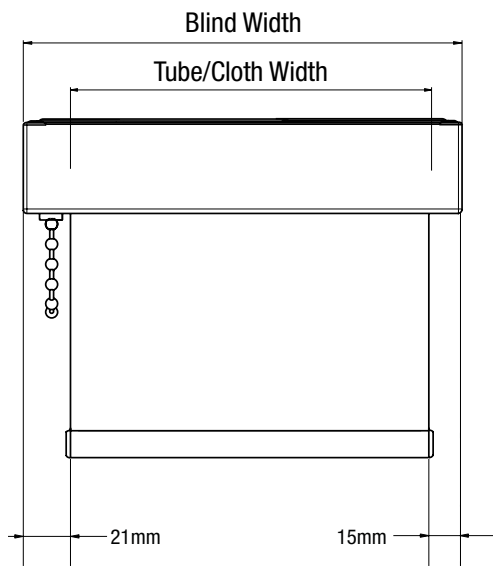

In situations where you require additional light control a matching one piece side channel system is available and easy to install.

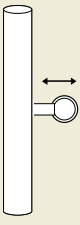

Exploded view diagram of headbox with side guide

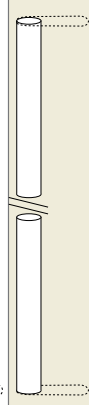
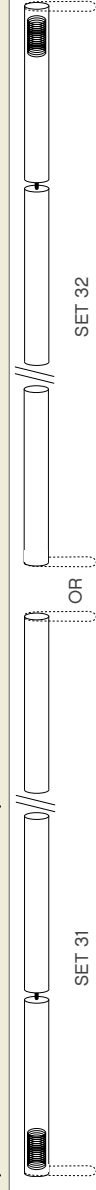
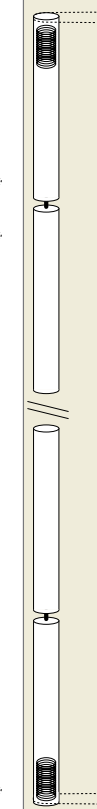
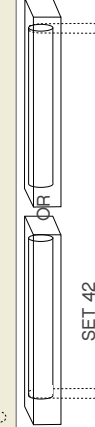
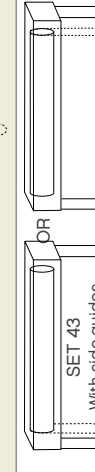

Single roller sets

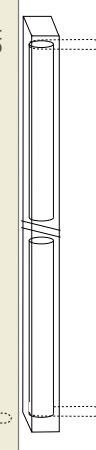
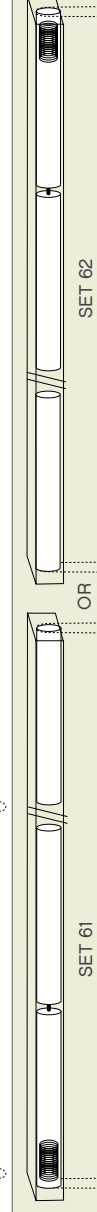
Set 10		Spring roll up. Minimum width 600mm, maximum width 2400mm.
Set 12		Single chain control roller. Left or right control.
Set 13		Single chain control roller. Left or right control. Supplied with stainless steel side guide wires.
Set 20		2 rollers linked together with inline joiner & soft lift. Left or right control.
Set 21		2 rollers with intermediate and 2 controls. Allows for individual control with reduced light gap.
Sets 31/32		3 rollers with 1 inline joiner, 1 intermediate & 1 soft lift. 2 controls. Allows 2 blinds to operate together and 1 independently.
Set 35		4 rollers with 2 inline joiners. 2 controls, 2 soft lifts. With intermediate in centre.
Sets 42/43	 	Set 42: Single chain control with cassette head box. Left or right control. Set 43: As above with side guides. Eliminates all light gaps.
Set 50		2 rollers linked together with inline joiner & soft lift in cassette head box. Left or right control.
Set 51		2 rollers with intermediate and 2 controls in cassette head box. Allows for individual control with reduced light gap.
Sets 61/62		3 rollers with 1 inline joiner, 1 intermediate & 1 soft lift in cassette head box. 2 controls. Allows 2 blinds to operate together and 1 independently.

Universal bracket angled options - up to 45°

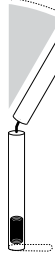

SET 23

2 rollers with 1 universal joiner & 1 control with soft lift. L or R (Minimum soft lift size 800mm).



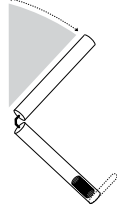

Universal bracket angled options - 45° to 90°

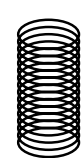

SET 24

2 rollers with 1 universal joiner & 1 control with soft lift. L or R (Minimum soft lift size 800mm).

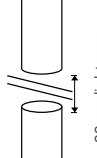
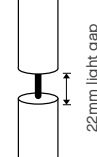
Legend



	Soft lift spring assist Allows heavy fabrics and inline sets to be lifted with ease. Minimum width = 800mm		Height 69mm, Depth 64mm		22mm light gap		22mm light gap		22mm light gap
		Cassette box Conceals roller and operating system inside a stylish cassette box.		Intermediate bracket Replaces 2 brackets with 1, reducing the light gap & allows 2 blinds to operate independently.				Inline joiner bracket Allows two blinds to operate together with one control. Reduces light gap.	

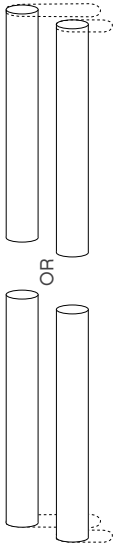
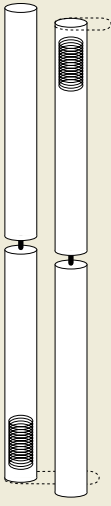
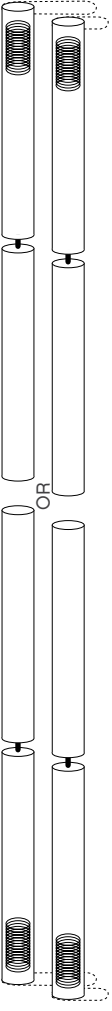
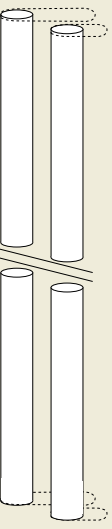
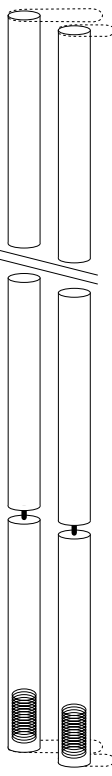
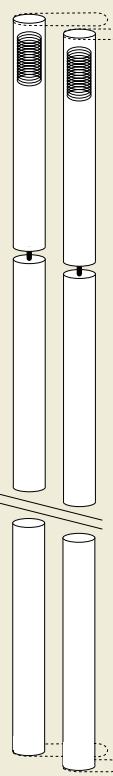

- Please note for angled options and combinations not included in the above a speciality sheet is required. All combinations and diagrams are viewed and measured left to right.
- **Automation:** All sets can be automated except set 10.
- **Recommended maximum sizes for inline joiner system with soft lift:** Maximum size for 2 linked blinds is 2500mm width x 2500mm drop = 5000mm of overall width.

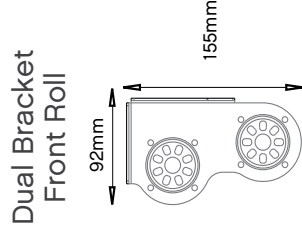
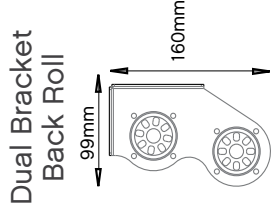
Twin roller sets

Set 71	Twin roller with controls at the same end left or right control. Square bracket.	
Set 80	2 twin rollers linked together with inline joiner. Controls at opposite ends with soft lift. Standard / slimline bracket.	
Set 81	2 twin rollers linked together with inline joiner, controls at the same end with soft lift. Left or right control. Square bracket.	
Set 82	2 twin rollers with intermediate bracket, 2 controls at each end and reduced light gap. Square bracket.	
Sets 92	3 twin rollers with 1 inline joiner and 1 intermediate. 2 soft lifts, 2 controls at each end. Allows 2 sets of blinds to operate together and 1 independently. Square bracket.	
Set 93	3 twin rollers with 1 inline joiner and 1 intermediate. 2 soft lifts. 2 controls at each end. Allows 2 sets of blinds to operate together and 1 independently. Square bracket.	

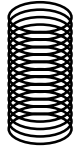

Legend	
	Back roll
	Front roll
	Back & front roll

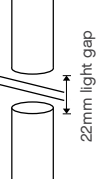
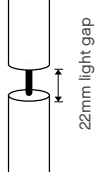
Legend			
	Soft lift spring assist Allows heavy fabrics and inline sets to be lifted with ease. Minimum width = 800mm		Cassette box Conceals roller and chain control inside a stylish cassette box.
	Intermediate bracket Replaces 2 brackets with 1, reducing the light gap & allows 2 blinds to operate independently.		Inline joiner bracket Allows two blinds to operate together with one control. Reduces light gap.

- Please note for angled options and combinations not included in the above a speciality sheet is required. All combinations and diagrams are viewed and measured left to right.
- **Recommended maximum sizes for inline joiner system with soft lift:** Maximum size for 2 linked blinds is 2500mm width x 2500mm drop = 5000mm of overall width.

Mechanism and light gap dimensions (37-50mm Roller Tube Applications)

Standard spring control set 10

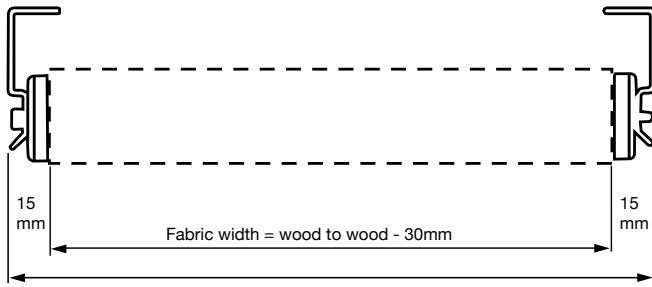

Standard chain control set 12

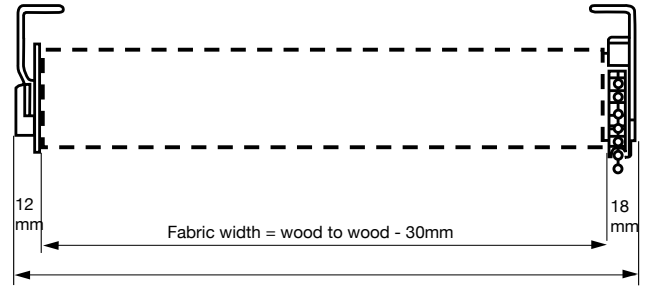

**Chain control set 20
Two blinds with one inline
joiner bracket. One control.**

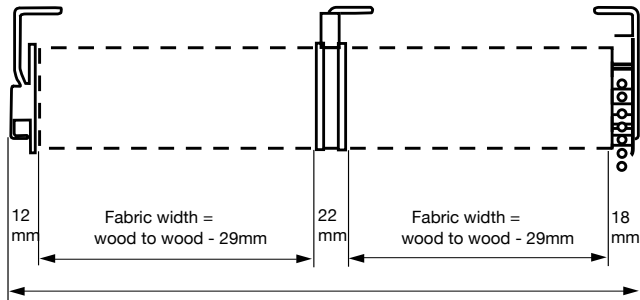

**Chain control set 31 & 32
Three blinds with two inline
joiner brackets. Two controls.**

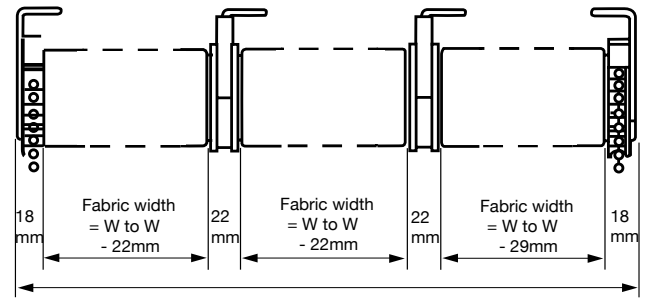

**Chain control set 21
Two blinds with one inline
joiner bracket. Two controls.**

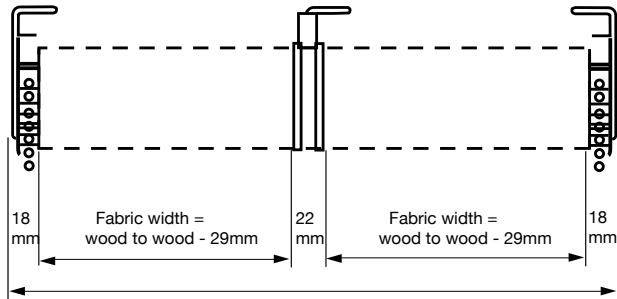

Automated system set 12

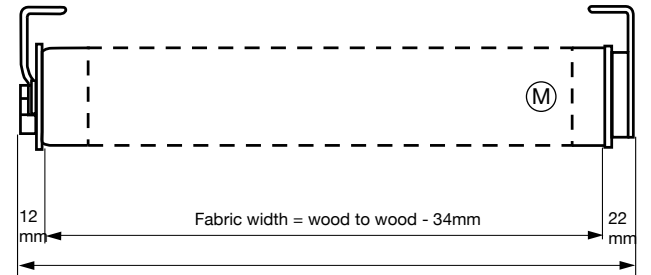

**Automated system set 20
Two blinds with one inline
joiner bracket. One motor.**

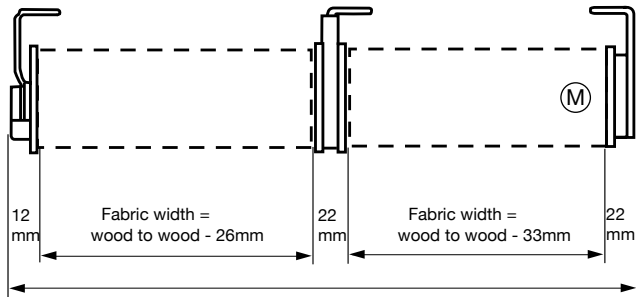

Mechanism and light gap set 13



Construction & Specification

Bottom Rail

Luxaflex® bottom rails are manufactured from extruded aluminium with a heavy duty powder coated finish that is available in a variety of colour and design options. These options provide the finishing touch to your blinds while being an integral design feature. The bottom rails are designed to provide both weight and rigidity to the fabric. This results in the fabric hanging flatter in the window and also contributes to the roll up performance of your Luxaflex® Rollershades.

Colour Options: White, Black, Ivory, Pearl, Bronze and Anodized Silver.



Gallery exclusive* Balance Bottom Rail

The Luxaflex Elliptical Balance bottom rail features a sound proofing bumper with a 60% increase in weight, ensuring fabric hangs and rolls very straight – meaning blinds look great and last longer.



Black, White, Anodised Silver, Magnolia, Shoji White, Granite, Gunmetal, Bronze, Limestone and Dune.

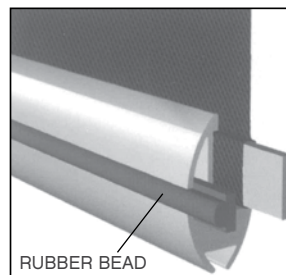

Size: depth = 16mm
Height = 32mm

**Balance Bottom Rail is only available through official Luxaflex Gallery stores throughout New Zealand. For a full list of Luxaflex Gallery dealers please visit www.luxaflex.co.nz*

Improved Ellipse Balance Rail

The Quantum Hardware System is available with the Ellipse Balance Rail which features a sound proofing bumper and has been designed with perfect weight distribution in mind to ensure fabrics hang very flat.

The Ellipse Balance Rail is now available in 10 colours, which includes the original Black, White, Magnolia and Silver Anodised.

The new colour options are Gunmetal, Granite, Limestone, Bronze, Dune and Shoji White. Four new end caps have been introduced to stylishly co-ordinate with the Ellipse bottom rail.

The internal design of the Ellipse Balance bottom rail has been re-engineered to improve the finished blind quality. This reduces fabric reworks caused by scratching and stretching as the fabric runs through the balance rail during fabrication.

Inner Strength

The aluminium tube is available in three sizes - 37mm, Heavy Duty (HD) 37mm and 50mm. Each tube has been engineered to perform to the highest standard with minimal deflection over large expanses. The skin can be applied to both the HD 37mm and 50mm tubes with either tape or spline.



Rollershade Bracket Systems

Quality Aesthetics

Components are available in four colour options - White, Black, Silver Anodised and Magnolia. All brackets are universal which reduces the likelihood of supplying incorrect components. Two bracket sizes are available, 38mm and 55mm which ensures the correct bracket can be selected for challenging installations and maximises the drop capacity. Brackets are available with end caps which are recommended for all face fit installations.

Single Bracket

38mm bracket dimensions

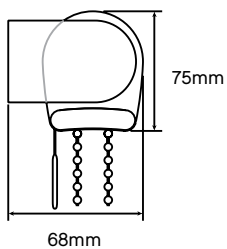

55mm bracket dimensions

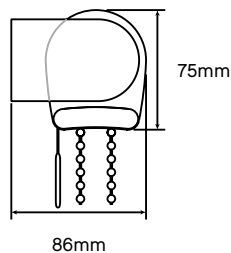

Adjustable Leveller Bracket

The adjustable leveller bracket allows the installer to adjust the blind for windows that are not square. This can also be used to adjust light gaps on linked blinds. (Please refer Luxaflex price book for surcharge).

Single Bracket Cover



Twin Roller Brackets

Back Roll Bracket

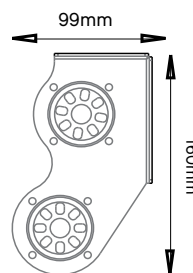

Front Roll Bracket

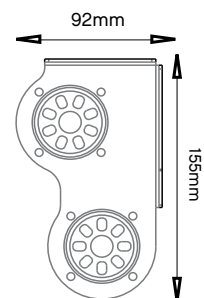

Two compact dual bracket designs are available:

- The standard (back) roll configuration ensures the blind skin can be fitted close to the window.
- The reverse (front) roll configuration provides self pelmet effect, covering the low blind and is available with same side controls.

Both dual brackets have universal mounting options (top or face installation) and can be used in conjunction with the linking systems.

Dual Roll Configuration

Two Dual Bracket systems are available. The standard roll bracket has been designed to keep your blind skins as close to the window as possible, whilst the reverse roll bracket provides a self pelmet effect and is ideal for use with fabrics that have a neutral toned backing. Blinds can be installed using either same side or opposite end controls.

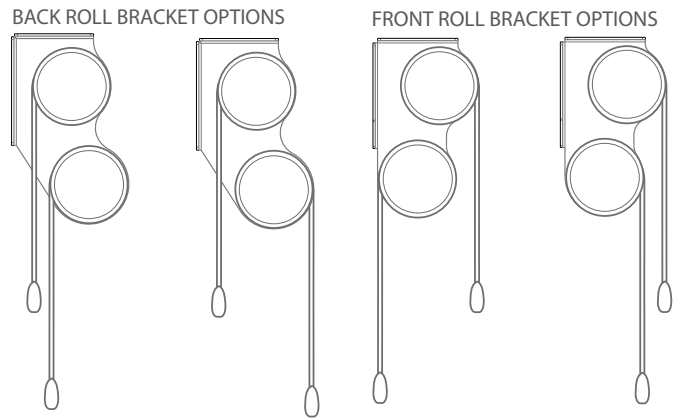

Single Bracket – Recessed Head Detail (Minimum Requirements)

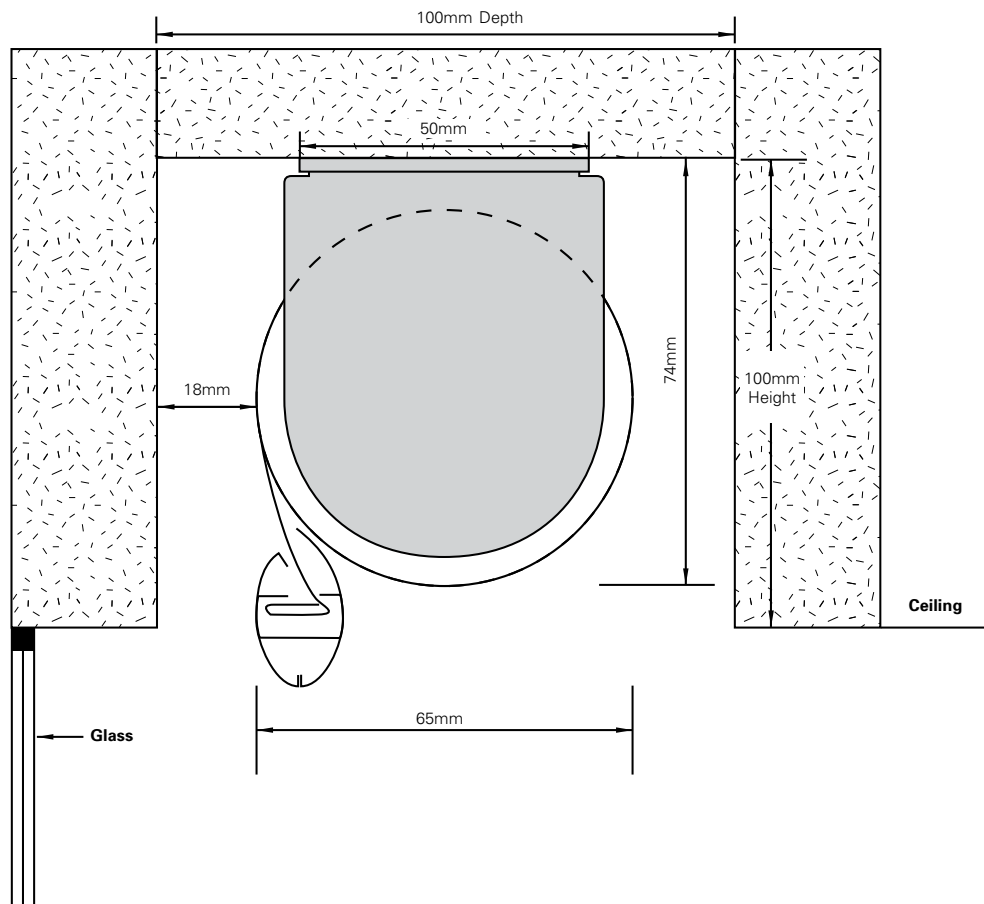

Double Bracket – Recessed Head Detail (Minimum Requirements)

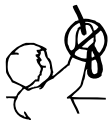
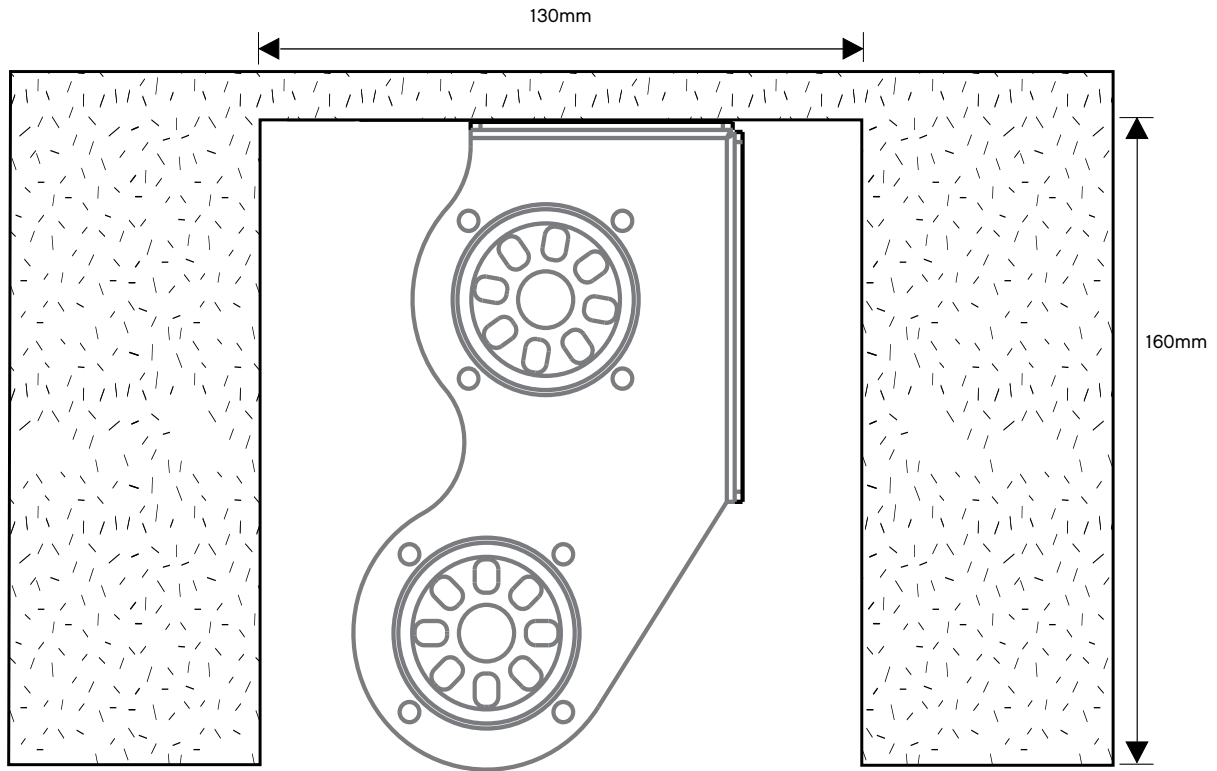

Chain Tensioners

Powder coated steel tensioners are available in inside fitting and face fitting applications. Available in white, ivory, black or grey.

Inside Fit

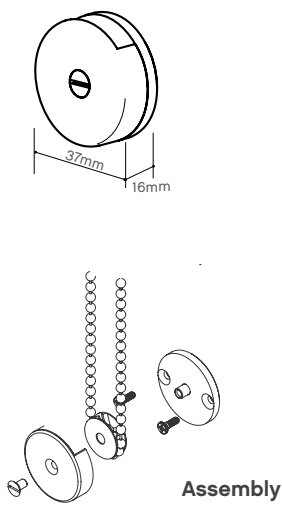

Face Fit

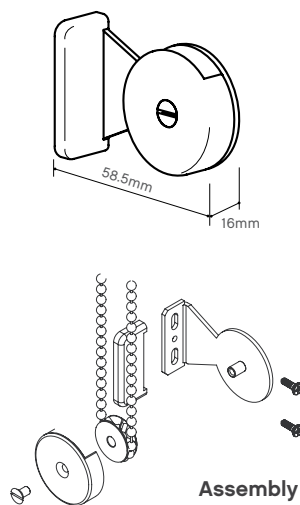

Clear plastic universal chain tensioners for face fix inside fitting applications (Item code: 32.798.000)

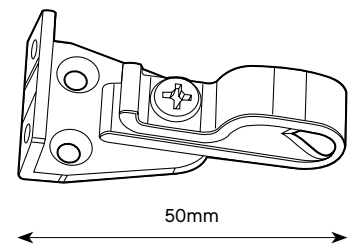

Set 13 – Wire Guide System

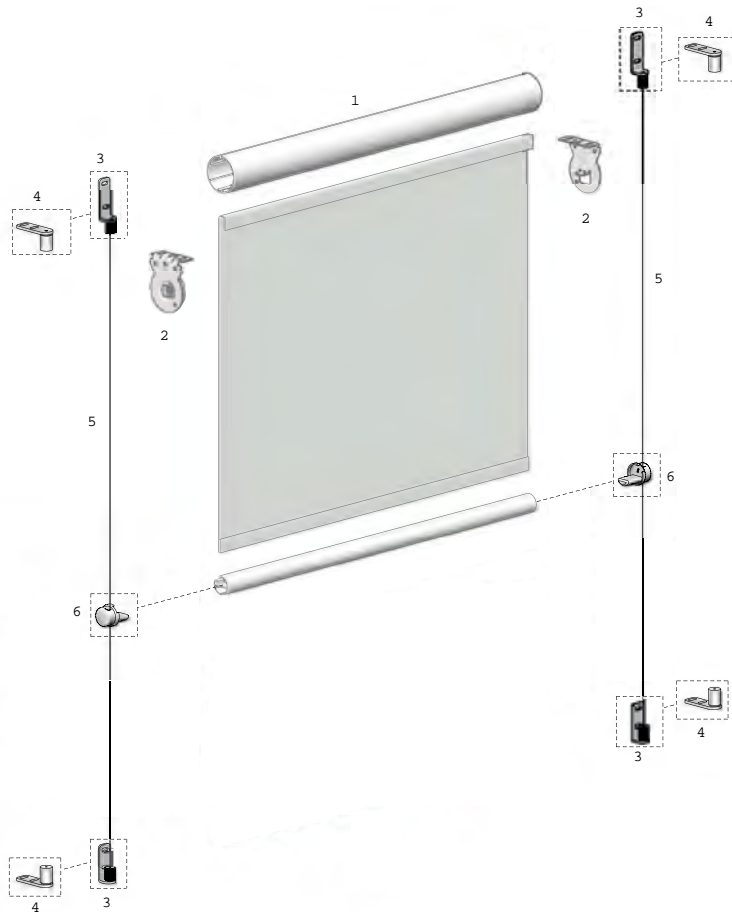

System Index

1. Aluminium Tube
2. Easy-Lock Bracket - VX
3. Tensioning Wire Stopper + Adjuster - Face/Wall Fix
4. Tensioning Wire Stopper + Adjuster - Top/Ceiling Fix
5. Wire Guide Tensioning Cable
6. Round Bottom Rail - Wire Guide End Cap

Features

- Tensioners available to suit Top or Face Fix applications
- Adjustable wire barrel attachment
- Wire guide end caps available for round bottom rails
- 1.2mm stainless steel tensioning cable
- Available in Zinc Plated finish
- Fabric gap = 34mm
- Ideal for fitting rollerblinds or sunscreens to doors or raked windows

Fixing Options

Face/Wall fix

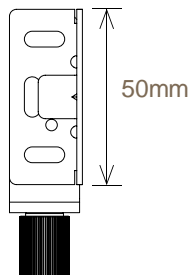
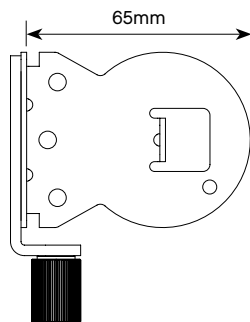

Top/Ceiling fix

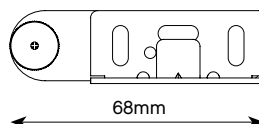
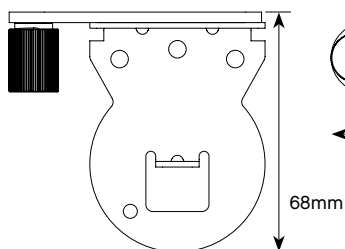
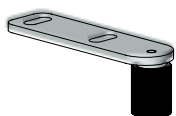

Round bottom rail
Wire guide end cap



Black, white, grey, ivory

Operation Type Limitations (For single blinds and linked systems)

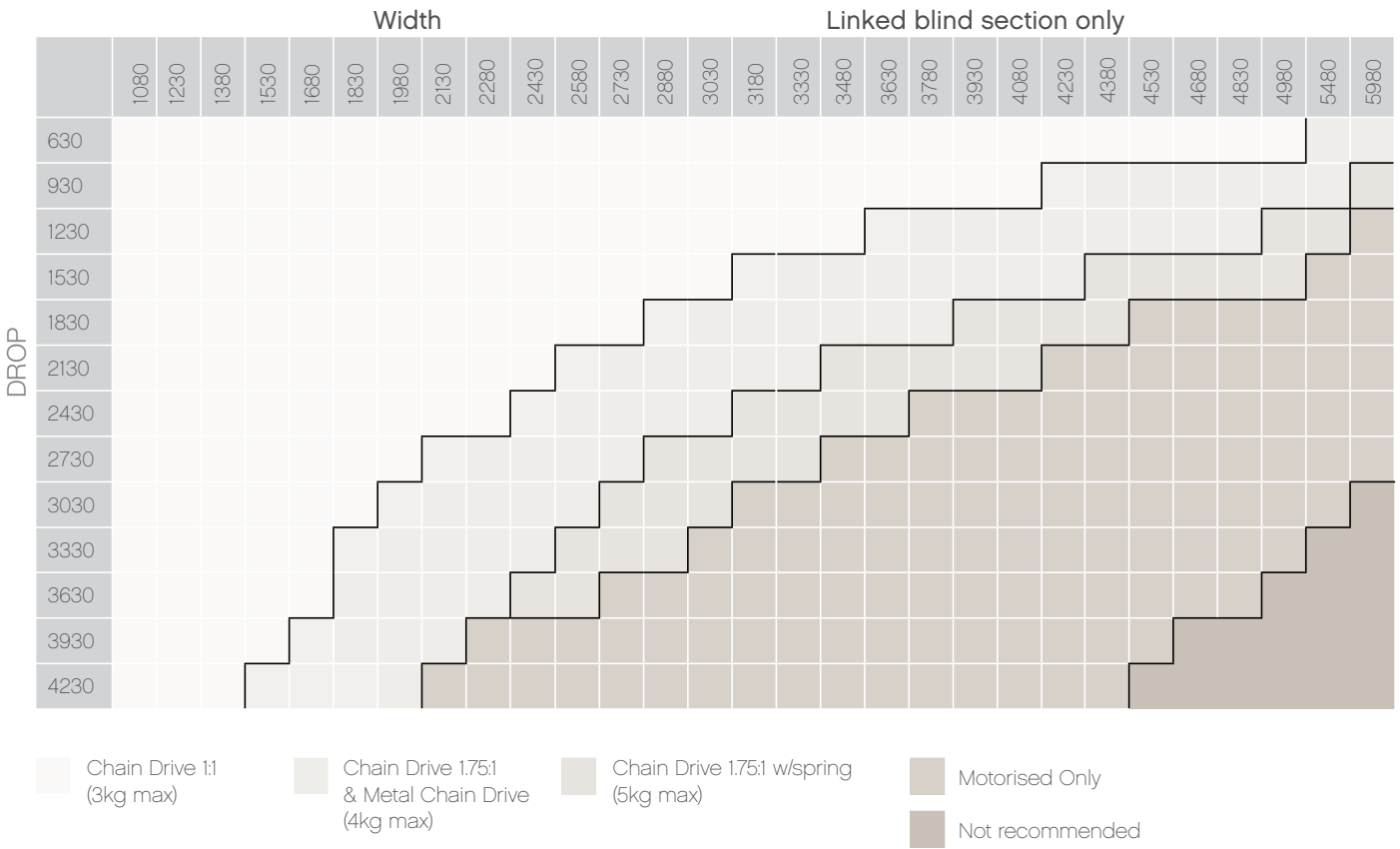

Fabric Specification Guide

Fabric	Roll width (mm)	Average openness factor	Composition	Sanitized® (bacteria resistant)	Duraguard® stain protection	Oeko-tex certified	Fire retardant	Fabric weight	Construction	Notes
Lavista	3000	5%	Polymer Coated Polyester				✓	490 GSM	2 x 2 basket weave	
Designer Series	3000	5%	22% Polyester 78% PVC				✓	470 GSM	2 x 2 basket weave	
Landscape	2500 (3000 selected colours)	6%	Polymer Coated Glass Fibre				✓	410 GSM	2 x 2 basket weave	
Silverscreen	2400	4%	Metallised PVC Coated Glass Fibre			✓	✓	400 GSM	1 x 2 basket weave	Metallised backing

Sunscreen

Fabric	Roll width (mm)	Average openness factor	Composition	Sanitized® (bacteria resistant)	Duraguard® stain protection	Oeko-tex certified	Fire retardant	Fabric weight	Construction	Notes
Zen	2800	-	100% Polyester				✓	350 GSM		Durable solid coated - easy clean
Harlow	2800	-	100% Polyester	✓	✓		✓	566 GSM	Layered honeycomb pattern	Tonal foam backing
Plaza	2400 (2800 selected colours)	-	100% Polyester	✓	✓		✓	375 GSM	Plain woven	Streetside colour
Atmosphere	2800	-	100% Polyester	✓	✓	✓	✓	420 GSM		White foam backing

Rollershades

Note: Please refer to www.luxaflex.co.nz for Solar Optical Properties for each fabric.



New Zealand Window Shades Ltd.

PO Box 12 785, Penrose
Auckland 1642
New Zealand

Call free 0800 223 224

Luxaflex® is a division of New Zealand Window Shades Ltd.
©Copyright 2014 New Zealand Window Shades Ltd.